



TEST REPORT

No. : SC100220105

Date : Mar. 11,2010

Page: 1 of 14

T F JACKSON PORTABLE ACCOMMODATION LTD
UNIT 25 HARPUR HILL BUSINESS PARK HARPUR HILL BUXTON DERBYSHIRE SK17 9JL

The following sample(s) was/ were submitted and identified on behalf of the client as:

Sample Name : Panel for T F Jackson Portable Accommodation Ltd
Sample Number : SC100220105
Test Required : Fire resistance (60 min)
Test Method : Please see next pages
Product specification : 60mm
Manufacturer : Wujiang Jiang Nan Purification Engineering Co., Ltd
Date of Receipt : Feb. 05,2010
Test Period : Feb. 05,2010 to Mar. 11,2010
Test result(s) : For further details, please refer to the following page(s)

***** To be continued*****

Signed for SGS-CSTC Standards
Technical Services (Shanghai) Co., Ltd

Sally Xie
Authorized signatory

This document is issued by the Company under its General Conditions of Service printed overleaf or available on request and accessible at http://www.sgs.com/terms_and_conditions.htm. Attention is drawn to the limitation of liability, indemnification and jurisdiction issues defined therein. Any holder of this document is advised that information contained hereon reflects the Company's findings at the time of its intervention only and within the limits of Client's instructions, if any. The Company's sole responsibility is to its Client and this document does not extend to any other parties to a transaction from exercising all their rights and obligations under the transaction documents. Any unauthorized alteration, forgery or falsification of the content or appearance of this document is unlawful and offenders may be prosecuted to the fullest extent of the law. Unless otherwise stated the results shown in this test report refer only to the sample(s) tested and such sample(s) are retained for 30 days only. This document cannot be reproduced except in full without prior approval of the Company.



6 Building, No.69 Block 1159-117 Building, Block 1365K, Angqiao East Road, Pudong Dist., Shanghai, China 201319 t (86-21) 68183233 /68183239 f (86-21) 68183122 /68183906 www.cn.sgs.com
中国·上海·浦东康桥东路1365弄17号楼/1159弄69号8号楼 邮编 201319 t (86-21) 68183233 /68183239 f (86-21) 68183122 /68183906 e sgs.china@sgs.com

SHML 157845



TEST REPORT

No. : SC100220105

Date : Mar. 11, 2010

Page: 14 of 14

Note 1,

T - The unexposed face temperature of the specified position, where the subscript number indicates the position of the thermocouple, which is state in the Photograph A.1.

Note 2,

The average initial temperature of the unexposed face of the specimen is 27.4°C;

The average temperature of the unexposed face of the specimen at the test terminated (62min) is 274.7°C;

So, the average temperature rise of the unexposed face of the specimen =274.7-27.4=247.3°C;

From the test data, the No. 5 thermocouple indicates the maximum temperature rise.

So, the maximum temperature rise of the unexposed face of the specimen =289.2-27.4=261.8°C.

At 20 minutes of test, the mean temperature and maximum temperature rise above the initial temperature, measured on unexposed face were 147.1°C and 163.7°C respectively.

***** End of report *****

This document is issued by the Company under its General Conditions of Service printed overleaf or available on request and accessible at http://www.sgs.com/terms_and_conditions.htm. Attention is drawn to the limitation of liability, indemnification and jurisdiction issues defined therein. Any holder of this document is advised that information contained hereon reflects the Company's findings at the time of its intervention only and within the limits of Client's instructions, if any. The Company's sole responsibility is to its Client and this document does not exonerate parties to a transaction from exercising all their rights and obligations under the transaction documents. Any unauthorized alteration, forgery or falsification of the content or appearance of this document is unlawful and offenders may be prosecuted to the fullest extent of the law. Unless otherwise stated the results shown in this test report refer only to the sample(s) tested and such sample(s) are retained for 30 days only. This document cannot be reproduced except in full without prior approval of the Company.

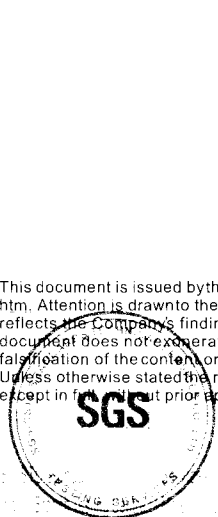



TEST REPORT

No. : SC100220105

Date : Mar. 11,2010

Page: 13 of 14

Time, min	Standard Temp. °C	Furnace Temp. °C	T ₁ °C	T ₂ °C	T ₃ °C	T ₄ °C	T ₅ °C
32	851	851	270.8	265.7	226.3	255.1	262.0
33	856	858	270.9	265.8	226.6	255.3	262.1
34	860	864	271.3	265.8	226.6	255.9	263.2
35	865	869	272.1	266.1	226.7	256.1	264.4
36	869	871	272.3	267.6	226.9	256.7	265.6
37	873	868	272.4	267.7	226.9	257.6	266.8
38	877	876	272.5	269.5	226.9	258.0	266.9
39	881	874	272.8	270.4	226.9	258.1	267.5
40	885	883	273.3	270.4	227.2	258.9	268.4
41	888	887	273.4	270.9	228.3	258.9	270.9
42	892	891	273.6	271.9	229.4	259.5	273.0
43	896	895	275.5	272.2	231.2	261.1	275.9
44	899	899	275.8	272.3	232.8	264.0	278.5
45	902	903	276.2	272.5	235.3	267.3	280.1
46	906	907	276.3	272.6	237.6	267.7	281.5
47	909	909	276.4	273.5	239.4	268.3	282.6
48	912	912	276.6	273.9	241.0	268.7	282.8
49	915	916	276.6	274.0	241.7	270.3	282.9
50	918	920	276.8	274.1	242.4	270.7	283.3
51	921	923	277.0	274.7	244.2	270.7	283.4
52	924	927	277.4	275.2	245.9	272.6	284.2
53	927	928	277.4	275.2	245.9	273.0	284.7
54	930	931	278.0	275.4	246.0	273.1	284.8
55	932	934	278.2	275.8	246.0	273.3	285.3
56	935	937	278.3	275.8	246.2	273.4	285.6
57	938	940	278.5	275.9	247.2	273.6	285.8
58	940	942	278.7	275.9	247.2	273.9	286.0
59	943	945	279.8	276.0	247.3	274.7	286.8
60	945	948	280.3	276.1	248.6	274.7	287.4
61	948	952	280.3	276.2	248.8	275.0	288.6
62	950	953	281.2	276.6	250.2	276.5	289.2

***** To be continued *****

This document is issued by the Company under its General Conditions of Service printed overleaf or available on request and accessible at <http://www.sgs.com/terms and conditions.htm>. Attention is drawn to the limitation of liability, indemnification and jurisdiction issues defined therein. Any holder of this document is advised that information contained hereon reflects the Company's findings at the time of its intervention only and within the limits of Client's instructions, if any. The Company's sole responsibility is to its Client and this document does not exonerate parties to a transaction from exercising all their rights and obligations under the transaction documents. Any unauthorized alteration, forgery or falsification of the content or appearance of this document is unlawful and offenders may be prosecuted to the fullest extent of the law.

Unless otherwise stated the results shown in this test report refer only to the sample(s) tested and such sample(s) are retained for 30 days only. This document cannot be reproduced except in full without prior approval of the Company.



3rd Building, No.66 Block 1159-17th Building, Block 1365K, Angqiao East Road, Pudong Dist., Shanghai, China 201319 t:(86-21) 68183233 /68183239 f:(86-21) 68183122 /68183906 www.cn.sgs.com
 中国·上海·浦东康桥东路1365弄17号楼/1159弄69号8号楼 邮编 201319 t:(86-21) 68183233 /68183239 f:(86-21) 68183122 /68183906 e sgs.china@sgs.com

SHML 157857



TEST REPORT

No. : SC100220105

Date : Mar. 11,2010

Page: 12 of 14

Appendix C Test temperature details

Time, min	Standard Temp. °C	Furnace Temp. °C	T ₁ °C	T ₂ °C	T ₃ °C	T ₄ °C	T ₅ °C
0	20	27	27.5	27.6	27.1	27.4	27.6
1	349	206	27.6	27.7	27.2	27.6	27.8
2	445	396	27.9	27.9	27.3	27.7	28.1
3	502	475	28.2	28.4	27.5	27.9	28.8
4	544	529	29.6	29.9	28.1	28.8	31.3
5	576	560	31.9	32.3	29.6	30.4	35.8
6	603	590	35.4	35.4	32.4	33.3	42.0
7	626	607	39.3	38.7	36.2	37.0	47.6
8	645	626	42.6	41.8	39.8	40.3	51.8
9	663	647	46.3	44.9	42.6	43.9	55.8
10	678	666	50.3	49.3	45.1	48.7	59.9
11	693	682	55.5	55.0	47.7	55.0	64.7
12	705	692	62.8	63.1	51.4	64.0	71.1
13	717	706	69.9	71.4	55.6	72.6	76.4
14	728	719	80.1	82.6	61.8	85.1	89.4
15	739	732	91.3	95.4	68.5	98.0	104.6
16	748	744	105.5	114.3	76.2	114.8	122.4
17	757	756	121.3	134.8	83.4	132.2	139.6
18	766	761	142.2	155.1	95.7	151.3	158.2
19	774	771	162.2	174.3	112.5	168.8	175.2
20	781	781	178.9	191.1	130.2	183.4	189.1
21	789	789	194.2	209.8	146.1	196.5	202.2
22	796	798	208.6	226.6	160.2	208.1	213.4
23	802	806	220.0	238.2	173.4	217.1	221.0
24	809	809	230.3	246.9	185.5	227.1	229.3
25	815	816	238.7	253.0	197.5	238.9	236.6
26	820	823	246.5	257.0	207.9	249.1	242.9
27	826	829	253.2	260.0	215.7	254.1	248.3
28	832	835	259.4	263.5	220.9	254.4	253.1
29	837	835	264.3	263.6	223.9	254.7	257.4
30	842	838	267.6	264.1	225.7	255.0	260.0
31	847	844	270.3	265.4	226.3	255.1	261.8

***** To be continued*****

This document is issued by the Company under its General Conditions of Service printed overleaf or available on request and accessible at <http://www.sgs.com/terms-and-conditions.htm>. Attention is drawn to the limitation of liability, indemnification and jurisdiction issues defined therein. Any holder of this document is advised that information contained hereon reflects the Company's findings at the time of its intervention only and within the limits of Client's instructions, if any. The Company's sole responsibility is to its Client and this document does not exonerate parties to a transaction from exercising all their rights and obligations under the transaction documents. Any unauthorized alteration, forgery or falsification of the content or appearance of this document is unlawful and offenders may be prosecuted to the fullest extent of the law. Unless otherwise stated the results shown in this test report refer only to the sample(s) tested and such sample(s) are retained for 30 days only. This document cannot be reproduced except in full without prior approval of the Company.



TEST REPORT

No. : SC100220105

Date : Mar. 11, 2010

Page: 11 of 14

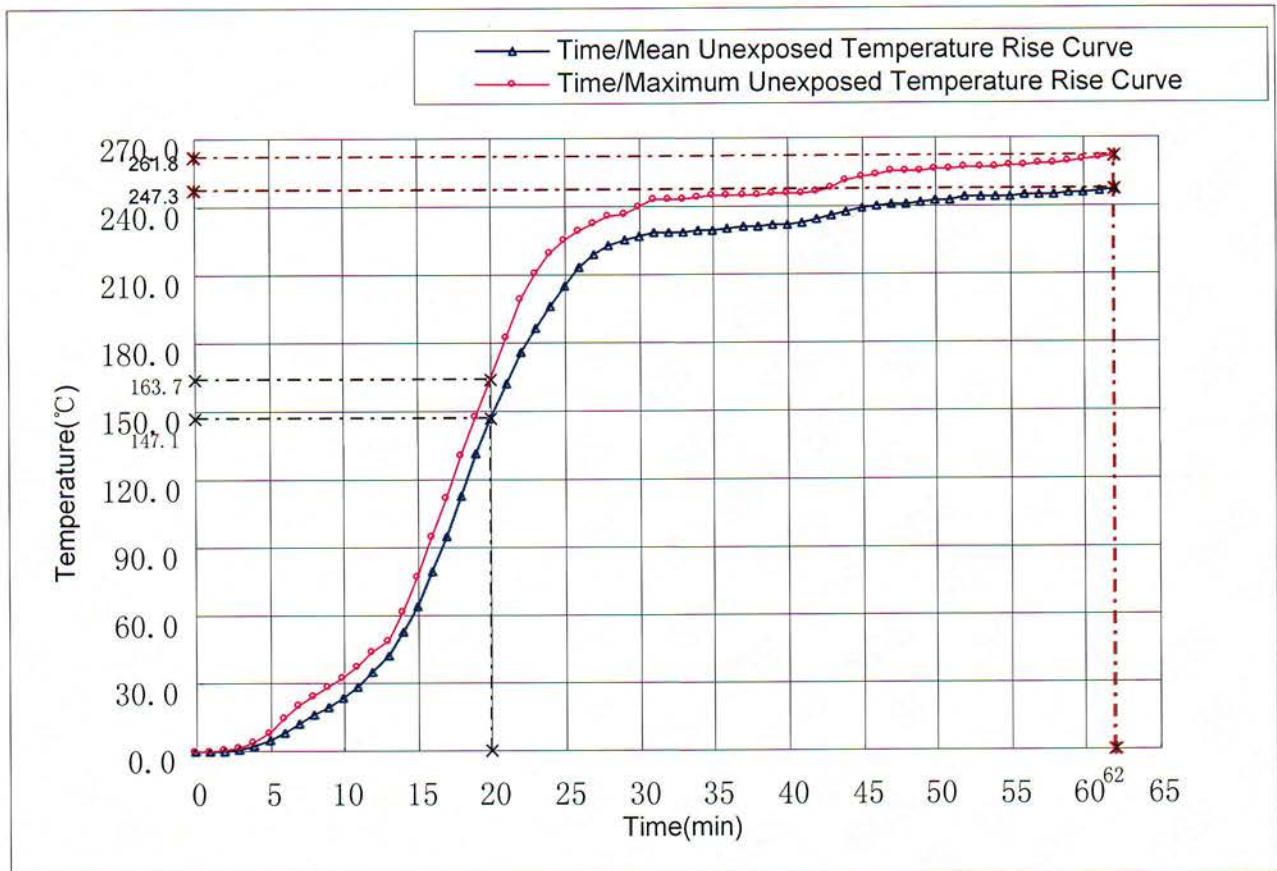

Figure B.2 Sample unexposed surface Temperature Rise

***** To be continued *****

This document is issued by the Company under its General Conditions of Service printed overleaf or available on request and accessible at http://www.sgs.com/terms_and_conditions.htm. Attention is drawn to the limitation of liability, indemnification and jurisdiction issues defined therein. Any holder of this document is advised that information contained hereon reflects the Company's findings at the time of its intervention only and within the limits of Client's instructions, if any. The Company's sole responsibility is to its Client and this document does not exonerate parties to a transaction from exercising all their rights and obligations under the transaction documents. Any unauthorized alteration, forgery or falsification of the content or appearance of this document is unlawful and offenders may be prosecuted to the fullest extent of the law. Unless otherwise stated the results shown in this test report refer only to the sample(s) tested and such sample(s) are retained for 30 days only. This document cannot be reproduced except in full without prior approval of the Company.

TEST REPORT

No. : SC100220105

Date : Mar. 11, 2010

Page: 10 of 14

Appendix B

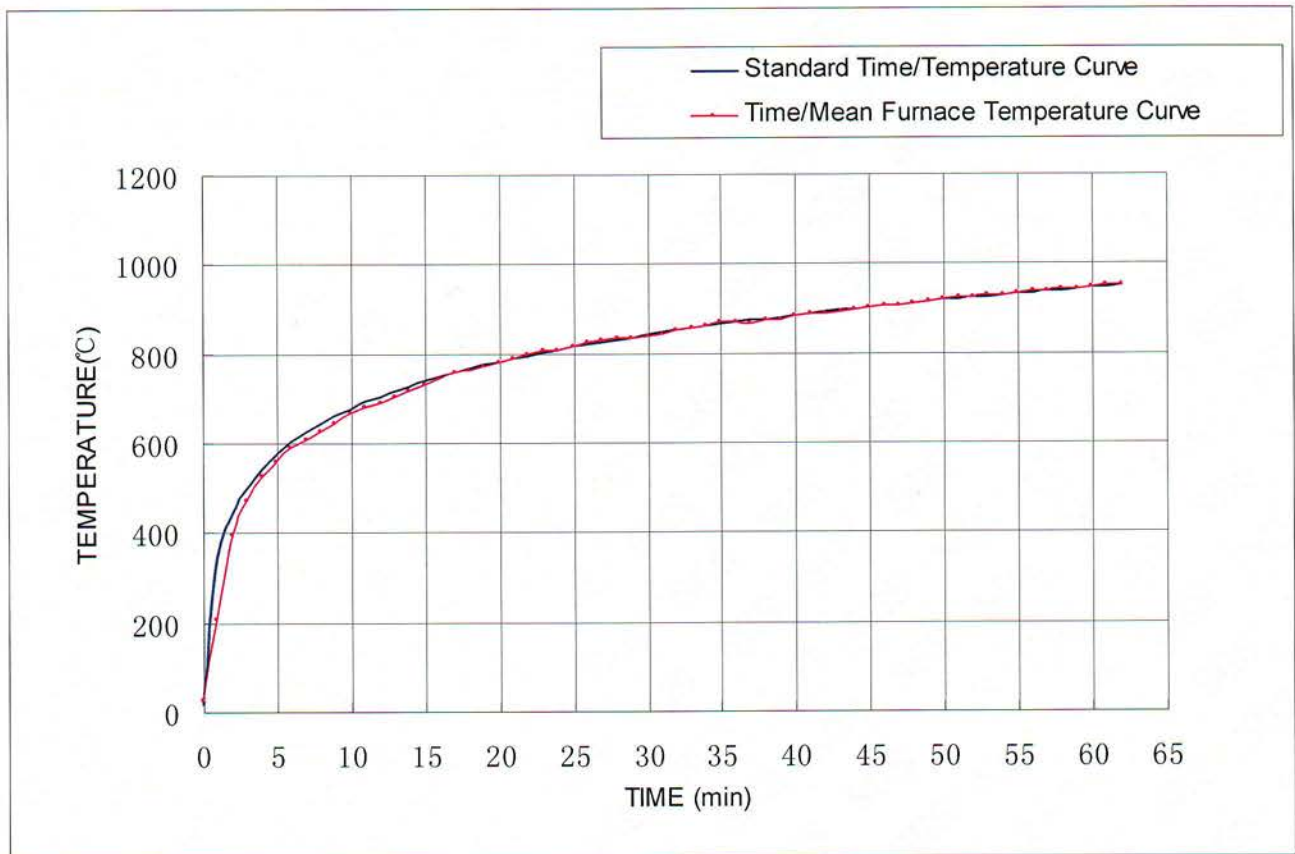

Figure B.1 Furnace Temperature
 ***** To be continued *****

This document is issued by the Company under its General Conditions of Service printed overleaf or available on request and accessible at http://www.sgs.com/terms_and_conditions.htm. Attention is drawn to the limitation of liability, indemnification and jurisdiction issues defined therein. Any holder of this document is advised that information contained hereon reflects the Company's findings at the time of its intervention only and within the limits of Client's instructions, if any. The Company's sole responsibility is to its Client and this document does not exonerate parties to a transaction from exercising all their rights and obligations under the transaction documents. Any unauthorized alteration, forgery or falsification of the content or appearance of this document is unlawful and offenders may be prosecuted to the fullest extent of the law. Unless otherwise stated the results shown in this test report refer only to the sample(s) tested and such sample(s) are retained for 30 days only. This document cannot be reproduced except in full without prior approval of the Company.

TEST REPORT

No. : SC100220105

Date : Mar. 11, 2010

Page: 5 of 14

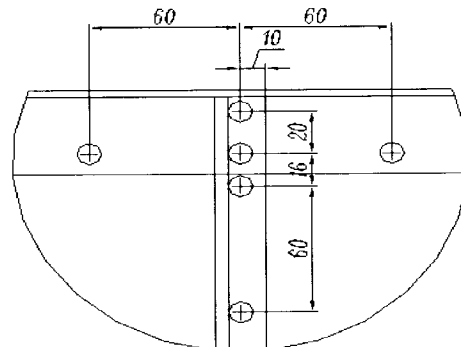
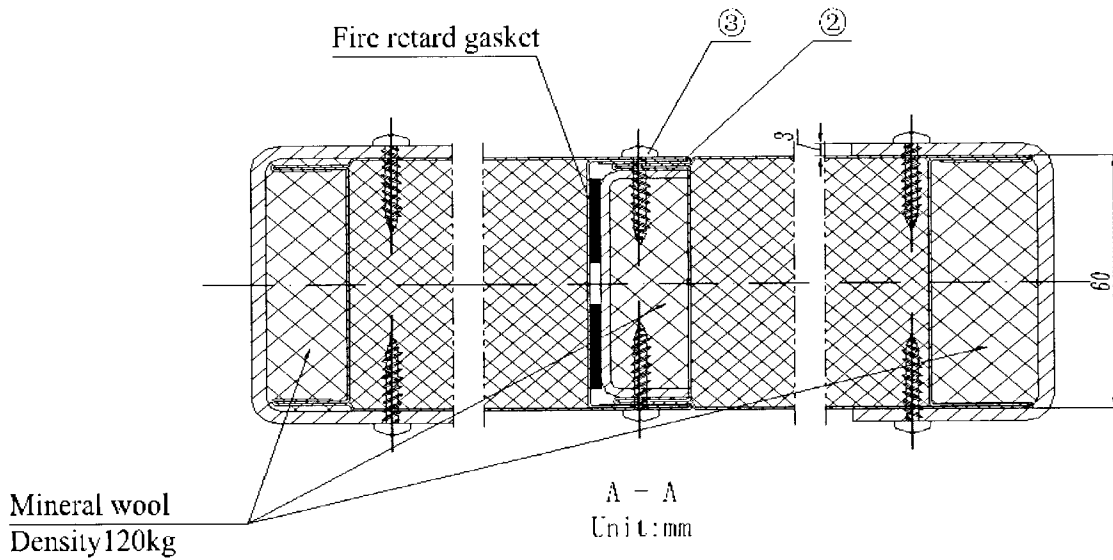

③	Screw	Stainless steel, ST4. 8X16	90
②	connection bar	Steel plate Q235/δ=2, bended	1
①	Sandwich Panel	0.5mm pre-paint steel sheet-59mm mineral wool (Density 120kg) 0.5mm pre-paint steel sheet	2
Item	Name	Material	Qty.

Photograph A.1 Specimen Structure Sketch

***** To be continued*****

This document is issued by the Company under its General Conditions of Service printed overleaf or available on request and accessible at http://www.sgs.com/terms_and_conditions.htm. Attention is drawn to the limitation of liability, indemnification and jurisdiction issues defined therein. Any holder of this document is advised that information contained hereon reflects the Company's findings at the time of its intervention only and within the limits of Client's instructions, if any. The Company's sole responsibility is to its Client and this document does not exonerate parties to a transaction from exercising all their rights and obligations under the transaction documents. Any unauthorized alteration, forgery or falsification of the content or appearance of this document is unlawful and offenders may be prosecuted to the fullest extent of the law. Unless otherwise stated, the results shown in this test report refer only to the sample(s) tested and such sample(s) are retained for 30 days only. This document cannot be reproduced except in full without prior approval of the Company.



TEST REPORT

No. : SC100220105

Date : Mar. 11, 2010

Page: 4 of 14

Appendix A

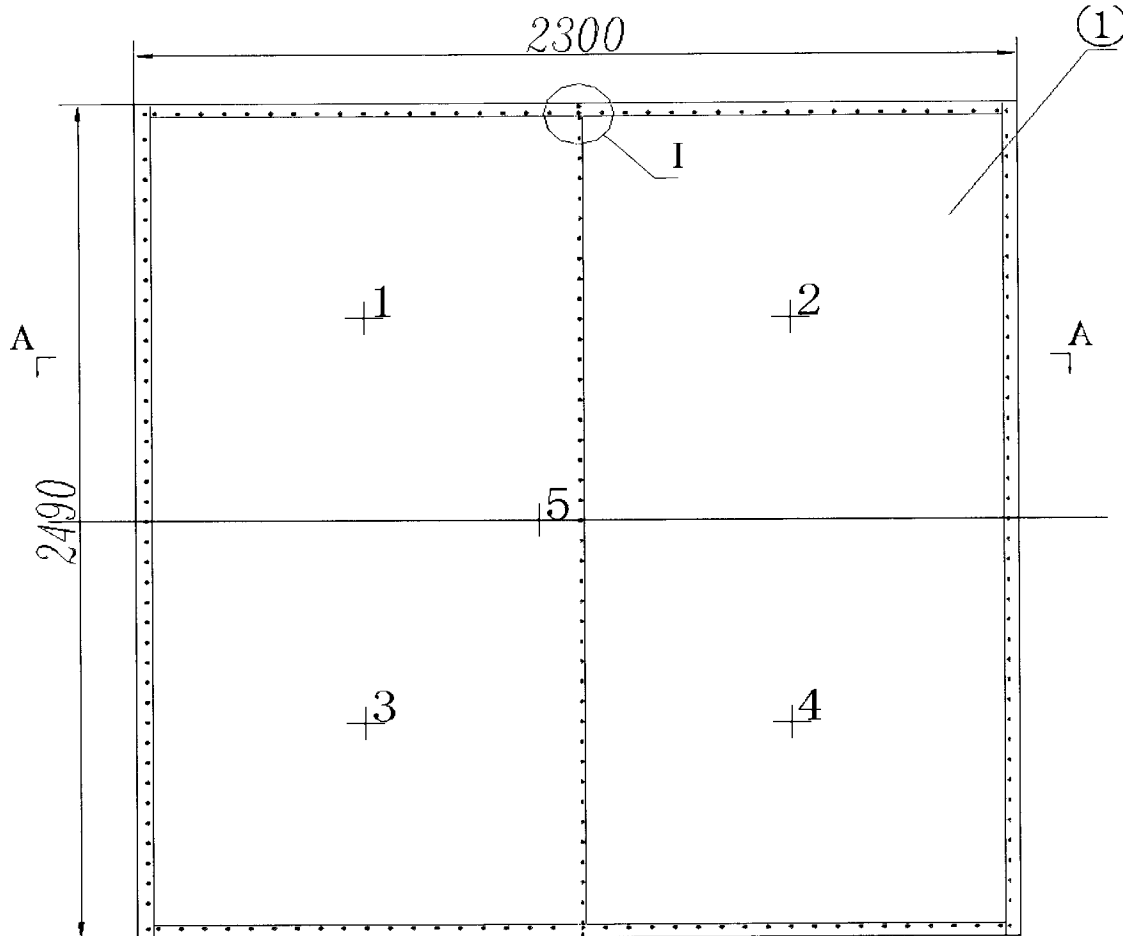

Structure sketch

Unit: mm

"+" Unexposed face thermocouple

***** To be continued*****

This document is issued by the Company under its General Conditions of Service printed overleaf or available on request and accessible at http://www.sgs.com/terms_and_conditions.htm. Attention is drawn to the limitation of liability, indemnification and jurisdiction issues defined therein. Any holder of this document is advised that information contained hereon reflects the Company's findings at the time of its intervention only and within the limits of Client's instructions, if any. The Company's sole responsibility is to its Client and this document does not exonerate parties to a transaction from exercising all their rights and obligations under the transaction documents. Any unauthorized alteration, forgery or falsification of the content or appearance of this document is unlawful and offenders may be prosecuted to the fullest extent of the law. Unless otherwise stated the results shown in this test report refer only to the sample(s) tested and such sample(s) are retained for 30 days only. This document cannot be reproduced except in full without prior approval of the Company.



TEST REPORT

No. : SC100220105

Date : Mar. 11, 2010

Page: 3 of 14

V. Test results

Test required	Test Standard	Technical requirements		Test Results (Time of test terminated)	Conclusion
Fire resistance	BS476:Part 22-1987	Lose Integrity	Sustained flaming for more than 10 seconds on the unexposed surface.	---	20 min, Lose Insulation
			Flames and/or hot gases cause flaming or glowing of the cotton fibre pad.	---	
			The 6 mm diameter gap gauge can penetrate a through gap such that the end of the gauge projects into the furnace and the gauge can be moved in the gap for a distance of at least 150 mm.	---	
			The 25 mm diameter gap gauge can penetrate a through gap such that the end of the gauge projects into the furnace	---	
		Lose Heat Insulation	The mean unexposed face temperature increases by more than 140 °C above its initial value.	The mean unexposed face temperature rise attained was 147.1 °C at 20 minutes.	
			The temperature recorded at any position on the unexposed face is in excess of 180 °C above the initial mean unexposed face temperature	---	
		Integrity failures	---		

The fire resistance test of the submitted sample:

Insulation: 20 minutes

Integrity: 62 minutes(no failure)

Note: The test was terminated at 62 minutes. Specimen photos before and after the test, see Appendix A, Photograph A.2

***** To be continued*****

This document is issued by the Company under its General Conditions of Service printed overleaf or available on request and accessible at http://www.sgs.com/terms_and_conditions.htm. Attention is drawn to the limitation of liability, indemnification and jurisdiction issues defined therein. Any holder of this document is advised that information contained here on reflects the Company's findings at the time of its intervention only and within the limits of Client's instructions, if any. The Company's sole responsibility is to its Client and this document does not exonerate parties to a transaction from exercising all their rights and obligations under the transaction documents. Any unauthorized alteration, forgery or falsification of the content or appearance of this document is unlawful and offenders may be prosecuted to the fullest extent of the law. Unless otherwise stated, the results shown in this report refer only to the sample(s) tested and such sample(s) are retained for 30 days only. This document cannot be reproduced except in full without prior approval of the Company.





TEST REPORT

No. : SC100220105

Date : Mar. 11, 2010

Page: 2 of 14

I. TEST CONDUCTED

British Standard 476, Fire tests on building materials and structures - Part 20-1987: Method for determination of the fire resistance of elements of construction (general principles) & Part 22-1987: Methods for determination of the fire resistance of non-loadbearing elements of construction.

II. SAMPLE DESCRIPTIONS

The specimen comprised mineral wool and steel sheets, nominally 2490 mm high × 2300 mm wide and Appendix A, Photograph A.1 illustrates the structure of sample.

III. EQUIPMENT:

FURNACE

The furnace has a nominal opening of 2490mm × 2300mm for attachment of vertical specimens.

TEMPERATURE:

The temperature in the furnace chamber was controlled in accordance with BS 476-20:1987, 3.1 Heating conditions and measured by five thermocouples.

The temperatures of the specimen were measured by glass-fibre insulated and sheathed K-type thermocouples with a wire diameter of 0.5mm.

PRESSURE:

The furnace pressure was measured by a differential low-pressure transducer.

IV. TEST DETAILS

AMBIENT TEMPERATURE: The temperature of the furnace chamber was 27.4°C at the commencement of the test.

***** To be continued*****

This document is issued by the Company under its General Conditions of Service printed overleaf or available on request and accessible at http://www.sgs.com/terms_and_conditions.htm. Attention is drawn to the limitation of liability, indemnification and jurisdiction issues defined therein. Any holder of this document is advised that information contained here on reflects the Company's findings at the time of its intervention only and within the limits of Client's instructions, if any. The Company's sole responsibility is to its Client and this document does not exonerate parties to a transaction from exercising all their rights and obligations under the transaction documents. Any unauthorized alteration, forgery or falsification of the content or appearance of this document is unlawful and offenders may be prosecuted to the fullest extent of the law. Unless otherwise stated, the results shown in this test report refer only to the sample(s) tested and such sample(s) are retained for 30 days only. This document cannot be reproduced except in full without prior approval of the Company.

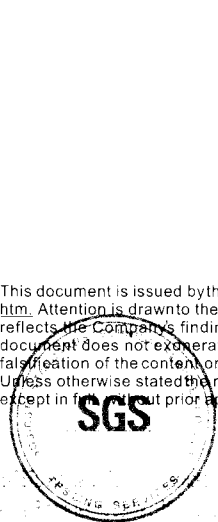

SHML 157846
8 Building, No.69, Box 169, 17 Building, Block 1365K, Angqiao East Road, Pudong Dist., Shanghai, China 201319 t(86-21) 68183233 / 68183239 f(86-21) 68183122 / 68183906 www.cn.sgs.com
中国·上海·浦东康桥东路1365弄17号楼/1159弄69号8号楼 邮编 201319 t(86-21) 68183233 / 68183239 f(86-21) 68183122 / 68183906 e sgs.china@sgs.com

Member of the SGS Group (SGS SA)